

UNION EUROPÉENNE DE GYMNASTIQUE
EUROPEAN UNION OF GYMNASTICS
EUROPÄISCHE TURNUNION



Secrétariat général
Avenue de Rhodanie 2
Case postale 975
CH - 1001 Lausanne
Tél.: +41 - 21 - 613.73.32
Fax : +41 - 21 - 613.73.31
E-mail: info@ueg.org
www.ueg-gymnastics.com

EUROPEAN CHAMPIONSHIPS IN TEAMGYM

DIRECTIVES For Equipment

September 2013
Revision A February 2016

Contents

INTRODUCTION.....	1
ART 1 GENERAL.....	2
ART 2 SUMMARY OF EQUIPMENT	2
ART 3 THE EQUIPMENT.....	2
3.1 FLOOR AREA	2
3.2 TUMBLING.....	3
3.2.1 TUMBLING TRACK.....	3
3.2.2 LANDING AREA.....	3
3.2.3 SAFETY STRIPS.....	3
3.2.4 ADDITIONAL SAFETY MAT.....	4
3.2.5 APPROACH RUN-UP	4
3.3 TRAMPET.....	4
3.3.1 THE TRAMPETS.....	4
3.3.2 VAULTING TABLE	6
3.3.3 LANDING AREA	7
3.3.4 SPACE PROBLEMS	7
3.3.5 ADDITIONAL SAFETY MAT.....	8
3.3.6 APPROACH RUN-UPS.....	8
3.3.7 Layout of Trampet	8
ART 4 CHECKING APPARATUS.....	8
APPENDIX A.....	8
A1 COMPETITION HALL LAYOUT	8
A2 EQUIPMENT DIMENSIONS.....	8
A3 TRAMPET DETAILS	8

ABBREVIATIONS

UEG: European Union of Gymnastics
TC-TG: TeamGym Technical Committee

Introduction

These regulations have been updated for the following reasons.

- To improve the visual aspects of the performances
- To improve the safety of the performers
- To standardise the equipment for fairness to all teams

One of the most important objectives is to try and ensure the standards for the equipment reflect an organised and safe sport. To achieve this, it is essential that all the equipment has a standard specification. These UEG directives and specifications are considered a minimum for international competitions.

©Drawings UEG

The following members of UEG TeamGym Committee contributed to this revision

Per Sjöstrand	President TC-TG
Heli Lemmetty	Vice President
Keith Hughes	Secretary (President up to December 2013)
Petr Gryga	Member
Rosa Dvoracek	Member (up to December 2013)
Solveig Jonsdottir	Member (from December 2013)

These revised Directives, which should be read in conjunction with the UEG TeamGym Equipment Standards, has gone through various development phases. They have been circulated to various Equipment suppliers so that comments can be considered. All feedback has been considered. The committee wish to express sincere thanks to everyone who put time into submitting comments.

Art 1 GENERAL

These Directives establish the minimal requirements for gymnastic apparatus used for the UEG TeamGym European Championships.

The Organising Committee of a UEG TeamGym Championships shall provide for all the necessary apparatus, which shall be in conformity with the UEG TeamGym Directives and TeamGym Equipment Standards in force at the time.

Before the event a representative of the TC-TG shall check the apparatus with the supplier on arrival.

Art 2 SUMMARY OF EQUIPMENT

The following equipment should be provided:

- Floor - A competition floor
- Tumbling - A sprung tumbling track, with run-up and landing area
- Trampets - A set of trampets, a vaulting table, with run-ups and a landing area.

All equipment must be in good condition. Trampets should be new.

The preferred configuration is shown in Appendix A1 – Competition Hall Layout. This requires a hall with a minimum size of 40 m by 28 m.

An identical set of equipment **MUST** be provided in the warm up gym which must be close by, together with suitable matted warming up facilities for all teams.

Art 3 THE EQUIPMENT

3.1 Floor Area

The floor exercise shall be performed on a 35 mm thick mat of carpet-bonded foam, with a marked performing area of 18 m x 14 m. (Note reduced size)

The outline of the performing area shall be marked with a 5 cm non-slip white line. This should be either painted or fixed to the mat with Velcro. The white line is part of the performing area and must be within the carpet-bonded foam area.

The mats shall be homogeneous and continuous. They shall be connected on their adjacent edges with 10 cm wide non-slip Velcro strips in matching colour to the mats. The Velcro strips shall be continuous and shall extend to the ends of the mat. The mats shall be placed in such a way as to avoid any movement or shift during the event. They shall be antistatic.

The UEG TC-TG in collaboration with the Organising Committee shall previously determine the colour.

Any banners and/or advertising signs may be fixed with Velcro to the free area, but there must be a significant colour difference. The advertising banner should not be less than 10 cm from the outside of the white line.

3.2 Tumbling

The equipment shall be composed of:

- an approach run-up
- a tumbling track
- a landing area
- safety areas
- an additional safety mat
- a fixed tape measure

3.2.1 Tumbling Track

The tumbling Track shall be 15 m long +/- 10 cm.

It shall be a minimum of 2 m wide and 35 cm high +/- 5 cm.

The surface of the tumbling track shall be completely even and without folds or joints. The side-lines and centre line should be marked with non-slip white lines 5 cm wide. The side-lines are part of the 2 m wide performing area.

The tumbling track must conform to the UEG TeamGym Equipment Standards.

3.2.2 Landing Area

The landing area shall be a minimum of 7 m long and 4 m wide.

The landing area shall be made of either a specially constructed one-piece landing area or a set of several standard mats of the appropriate size and construction. It shall be the same height as the tumbling track (+/- 5 mm). It must be designed for safe reception and absorption of the landing force. (See Standards)

The landing area has a Landing Zone 2 m by 4 m (+/- 5cm) plus a Safety Zone.

If several mats are used in the landing area, they shall be connected with at least a 10 cm Velcro flap. The Velcro connections should connect away from the gymnast's movement direction and not cause any trip hazards.

The Landing Zone should be marked in contrasting colour and it shall be possible to connect the additional safety mat to the front edge with Velcro (See 3.2.4).

The underside of the landing area shall be non-slip, so it will not move during use.

The tumbling track shall be connected to the landing area with at least a **15 cm** Velcro flap. The run-up shall be connected to it with at least a 10 cm Velcro flap.

3.2.3 Safety Strips

The safety strips are located at the sides of the track, near to the landing area.

They are each at least 0.5 m wide and a minimum of 3 m long. They shall start at the landing area and shall be fixed with a Velcro flap (min 10 cm) on both sides of the tumbling track.

3.2.4 Additional Safety Mat

An Additional Safety Mat is an optional soft mat 2 m by 4 m and 10 cm thick. It shall be possible to connect the safety mat to the front end of the landing area, with a Velcro connection (10 – 15 cm). On the tumbling track's Velcro flap, there must be soft Velcro on the upper side to connect the safety mat to it, if required.

3.2.5 Approach Run-up

The approach run-up shall be 16 m +/- 5 cm long and 1 m +/- 5 cm wide.
(Note Reduced length from 20m in previous code)

It shall be level with the tumbling track (+5/-0 mm).

It shall be covered with a non-slip material. The blocks that form the run up shall be connected with at least 10 cm Velcro flaps and it shall be fixed in such a way as it will not move or slide during the gymnast's rapid movements.

There shall be a smooth transition between the run up and the tumbling track. A 31 m tape measure must be attached to the floor at the side of the run up so as not to cause a trip hazard. It will measure distance from the start of the landing area. Adjacent to the run up, each meter should be clearly visible from the run up.

No personal markings will be allowed on the run up, the track or on the floor.

3.3 Trampet

The performing area shall be made of:

- a set of trampets
- a vaulting table (Pegasus)
- a landing area
- an approach run-up to the trampet
- a separate approach run-up to the vault
- an additional safety mat
- a tape measure

The Organising Committee shall provide a set of trampets, which meet the standards that are identified in 3.3.1 and the UEG TeamGym Equipment Standards.

3.3.1 The Trampets

General	Open-ended/lightweight trampets are not acceptable. Lightweight is less than 45 kg, measured ready to use, but without safety covers.
The frame	The top frame shall be constructed of round, square or rectangular hollow tube, approximately 5 cm thick. Legs and supporting parts can be made of larger profiles. No sharp edges are allowed.
Dimensions	The outside measurements of the top frame should be 120 cm (+/- 5 cm)

Height

Front part. 25 cm (+/- 1 cm) (non adjustable)
 Back part. 65 to 80 cm range in quick set heights of 65cm, 70cm, 75cm & 80cm. (+/- 1 cm)

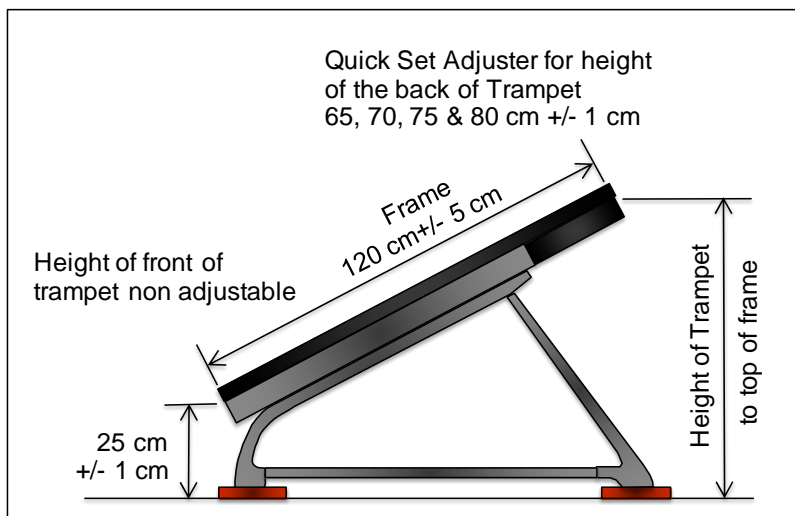

Springs

Only steel springs are acceptable. See the description of spring set-up for trampets under trampets.

Bed of trampet

60 cm x 60 cm (+/- 5 mm). A light coloured bed clearly different from the colour of the safety cover. The centre of the bed should be clearly marked. (For example: a circle, a plus sign or a cross - see below.) The bed should be made of a tight weave material, where the maximum dimension of the holes is 6 x 6 mm.

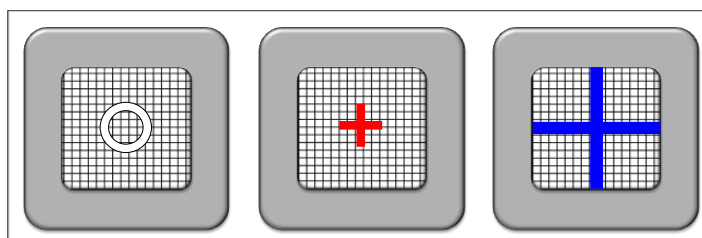

Safety covers

The upper side of the whole frame and all the springs shall be covered with a safety cover; minimum 3 cm thick. The free square space in the middle has a maximum size of 68 x 68 cm. The colour of the cover shall be clearly different from the colour of the bed.

Additional safety

The vertical protection is mandatory in the form of a piece of foam that protects the gymnasts from landing directly on to, or falling back on to, an exposed part of the trampet. The protection must be at least 3 cm thick.

Feet

All four feet shall have a non-slip surface with a minimum size of 10 cm by 10 cm.

Movement restriction	The trampets will have to pass the movement restriction test in the UEG TeamGym Equipment Standards. The stand alone trampet shall be set close to the landing area such that its feet are beneath the landing area.
Wheels	The trampets must have transport wheels on the one side, 2 – 4 pieces. They must be in good conditions.
Tension	The tension in the bed must meet the standards set out in the UEG TeamGym Equipment Standards.
Trampets	The organisers will provide a set of identical trampets for the training area and competition area, as defined above and in accordance with the specification. There will be trampets of at least two different tensions to choose from. These trampets will be clearly labelled Hard or Soft (or similar). The soft trampet has 36 steel springs and the hard trampet has 40. At each location there will be two trampets of each tension. These trampets will have quick adjustment of the back height. Coaches shall insure that they select and use their preferred trampet at the correct height setting.
Own Trampets	It is NOT allowed for teams to bring their own trampets. Should teams have particular need to bring their own trampet, they should apply to the UEG TC-TG, at least 3 months before the event. Approval will only be in exceptional circumstances and it will be subject to a UEG safety scrutiny and there will be a fee.

3.3.2 Vaulting Table

Type	The vaulting table shall comply with the latest UEG Equipment standards for a TeamGym vault.
Height	<p>Seniors: Women’s, Men’s and Mixed teams may use the vault at a variable height from 150 cm to 165 cm.</p> <p>Juniors: Girls, Boys and Mixed teams may use the vault at a variable height from 145 cm to 165 cm.</p> <p>The height is measured from the floor to the centre part of the table and the heights have been updated accordingly.</p> <p><i>(Note change - now the same as artistic gymnastics)</i></p> <p>The vault shall have a quick and easy adjustment in 5 cm steps, with marked height settings.</p>
Top part:	This shall be in accordance with UEG TeamGym Equipment Standards.

Construction: The structure part supporting the vaulting platform shall be a mono-stand. There shall be a height scale on the column and it shall have transport wheels. It should meet the UEG TeamGym Equipment Standards for safety

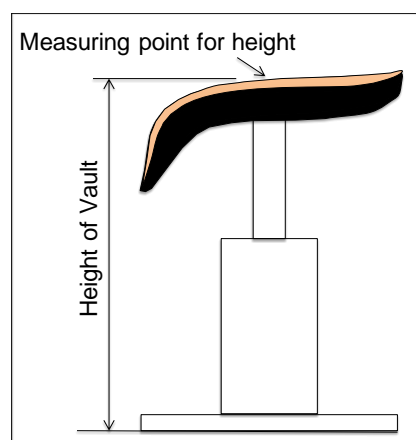

Stability In order to ensure safe usage, the vault should always be able to pass the UEG TeamGym Equipment Standards stability test.

Safety The leg and the construction beneath the vault should have safety padding on both front, back and sides.

3.3.3 Landing Area

Where possible, the landing area shall be a combined area for the trampet vault and the trampet on its own. It should then be a minimum of 7 m long and 7 m wide.

The landing area shall be made of either a specially constructed one-piece landing mat or a set of several standard mats of the appropriate size and construction. It shall be 35 cm high +/- 2 cm. It must be designed for safe reception and absorption of the landing force.

The landing area has two Landing Zones 2 m by 4 m (+/- 5cm) plus a Safety Zone and an additional safety mat.

If several mats are used in the construction of the landing area, they shall be connected with at least a 10 cm Velcro flaps. The Velcro connections should connect away from the gymnast's movement direction and not cause any trip hazards.

The Landing Zones shall be marked in contrasting colour and it shall be possible to connect the additional safety mat to them with Velcro.

The underside of the landing area shall be non-slip, so it will not move during use.

3.3.4 Space Issues

In less favourable circumstances, where only one trampet run up is possible, a trampet landing area can be created 7m x 4m. In such circumstances the vault would need to be moved in and out during the performance. In this situation, it will be announced with the details of the equipment.

3.3.5 Additional Safety Mat

An Additional Safety Mat is an optional soft mat 2 m by 4 m and 10 cm thick. It shall be possible to connect the safety mat to the front end of the landing area, with Velcro (10 – 15 cm).

3.3.6 Approach Run-Ups

The approach run-ups shall be 25 m +/- 5 cm long and 1 m +/- 5 cm wide and will be restricted to this length.

The run-up-mats shall be 25 mm thick.

They shall be covered with non-slip material and they shall be fixed in such a way as not to move or slide during the gymnast's rapid movements.

A 30 m tape measure must be attached to the floor between the two run-ups so as not to cause a trip hazard. It will measure distance from the start of the landing area. Adjacent to the run up, each meter should be clearly visible from the run up.

No personal markings will be allowed on the run up or on the floor.

3.3.7 Layout of Trampets

The diagram in Appendix A3 shows a felted non-slip timber plate beneath the trampets and the vault, which is the same thickness as the run-up mat. The run-up mat shall be fixed in position and taped to this plate with no gap. Please note that the trampet and vault will therefore be raised 25mm above the floor. Wooden blocks of various widths shall be provided to maintain the position of the trampet to the vault as required by each team.

Art 4 CHECKING APPARATUS

A representative of the TC-TG shall check the apparatus before the competition starts and shall authorise its use provided the safety and technical requirements conform to the regulations. This includes all trampets used at the event.

Appendix A

A1 Competition Hall Layout

A2 Equipment Dimensions

A3 Trampet Details

Changes included in Revision A:

- Document: Minor corrections to spelling and punctuation
- Article 3.2.1: Width of white line correction to 5 cm plus updated diagrams
- Article 3.3.2: Diagram showing height of vault to centre point
- Article 3.3.7: New layout of trampets describing the board beneath the trampet
- Appendix A1 & A2: Minor corrections to match text
- Appendix A3: The drawing has been updated to include the wooden board underneath the trampet and vault plus minor corrections to match text

UEG TeamGym Equipment – Appendix A1 Competition Hall Layout

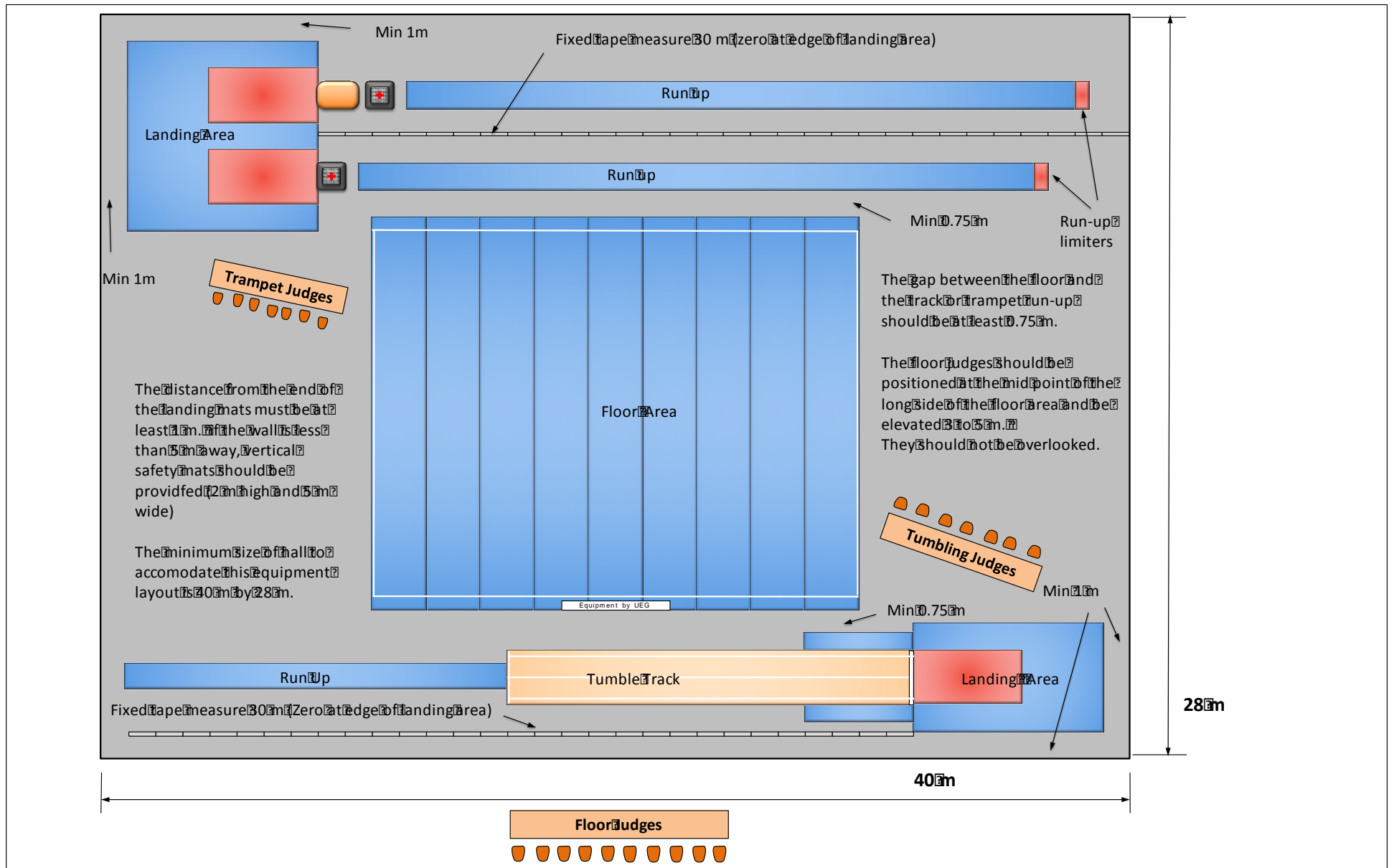

UEG TeamGym Equipment Appendix A2 Competition Equipment Dimensions

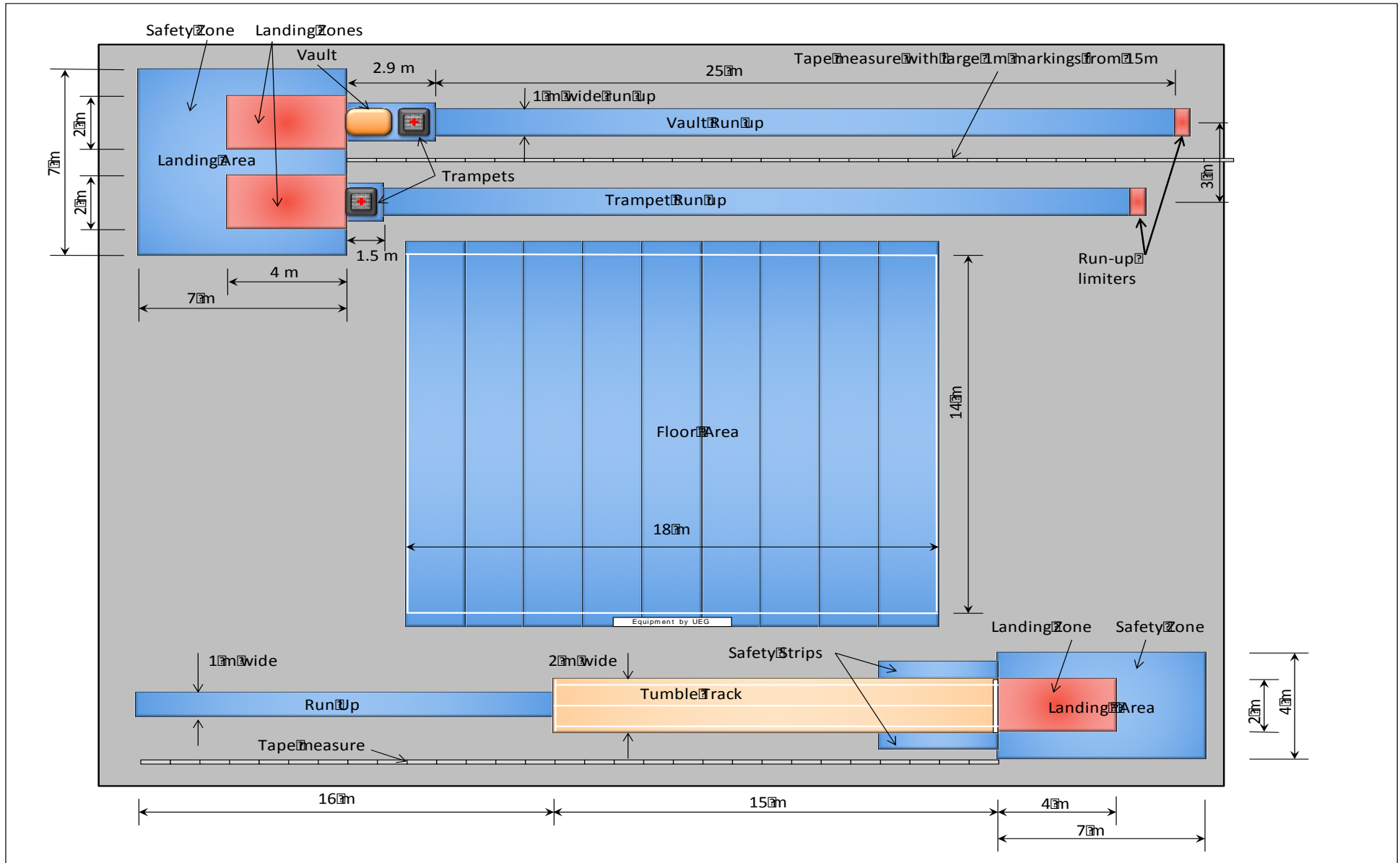

UEG TeamGym Equipment Appendix A3 Trampet and Vault Details

Trampet and Vault Set-up

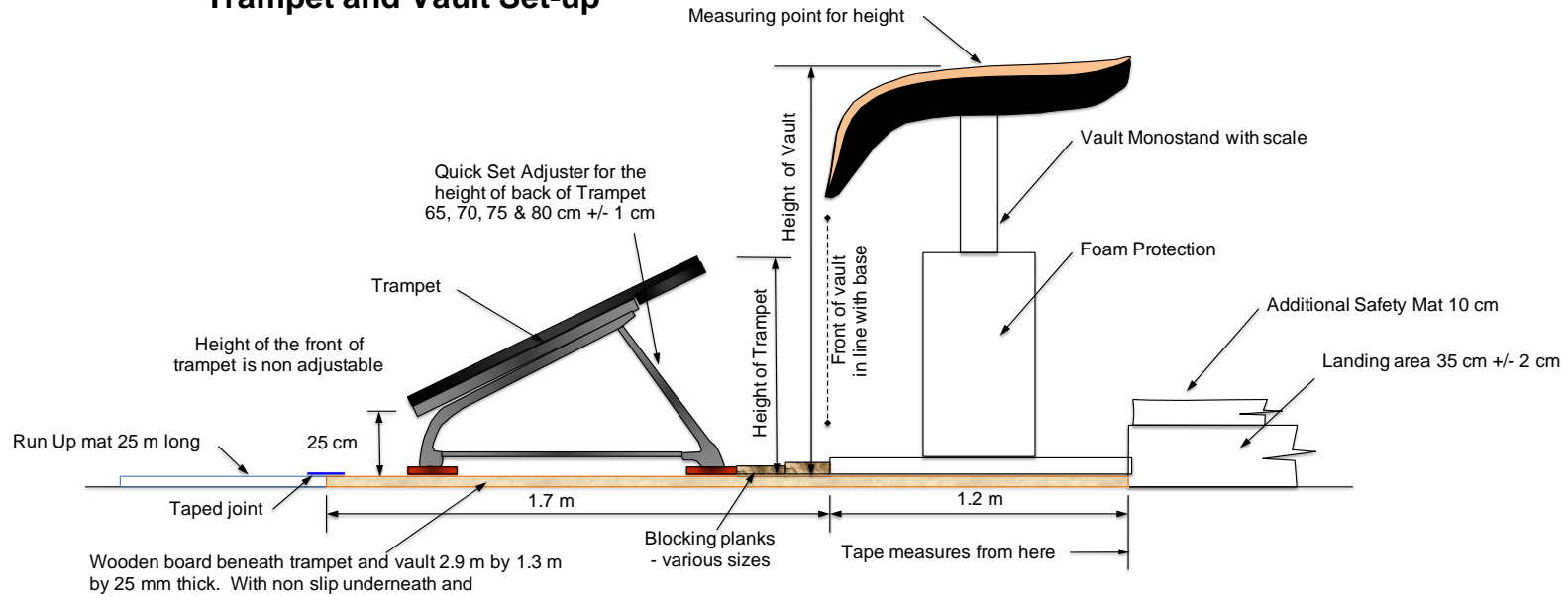

Trampet Stand Alone Set-up

